

TOOLS & ACCESSORIES

TOOLS AND ANCILLIARY PRODUCTS



Self Adhesive Patch Up Tape

- Supplied in 4 thicknesses - 35, 55, 75 and 90 microns
- 3mm and 6mm width
- 20 metres per roll

AVAILABLE IN **THREE THICKNESSES**

COLOUR CODE	MICRONS	WIDTH	REEL SIZE
Blue 	40	3mm 6mm	33mm
Red 	60	3mm 6mm	33mm
Yellow 	80	3mm 6mm	25mm



Shim Tape

- Steel strip for durability; will not compress
- .001" (25 microns), .002" (50 microns), .005" (125 microns)

10, 20 OR 30 METRES ROLLS



ER-1500

- Cyanoacrylate adhesive for flat bed dies
- 5 second dry time to position rubber
- 50g bottles



Tripplex Patch Sheet

- Calibrated for accuracy
- Totally no tear
- Moisture resistant
- Roll size 1200mm x 50m



CF-100

- Cyanoacrylate adhesive for rotary dies
- Instant dry
- 50g bottles

QUICK DRYING



Carbon Paper

- For making patch up sheets
- Roll size 1200mm x 900m



Plate Cleaner

- Citrus based plate cleaner

CHANNEL

THE WORLD'S MOST
ADVANCED CREASING
MAKE-READY SYSTEM

TOOLS & ACCESSORIES

TOOLS AND ANCILLIARY PRODUCTS



Manufactured under a quality system certified as complying with ISO 9001 by an accredited certification body.

12/09

018

TOOLS & ACCESSORIES

TOOLS AND ANCILLIARY PRODUCTS

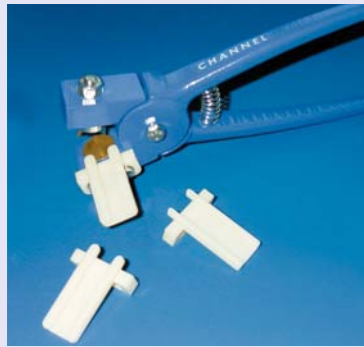

Metal Mitring Pliers

- Cuts 45° mitred angles
- Fits all matrix base widths
- Spare blade included

PLASTIC HANDLE
PLIERS ALSO
AVAILABLE



Perfix and Mini Perfix

- 14mm high
- 26mm high

TWO SIZES
AVAILABLE

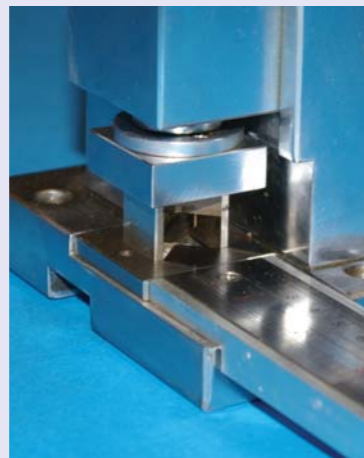

Supercut III Matrix Cutter

- Mitres both ends with one cut
- Suits all widths of matrix and centres automatically
- Punch type cutting tool
- Waste ejects below machine
- 45° & 60°

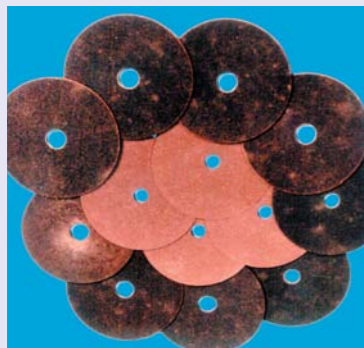

Nicking Discs

- A type: 50mm OD x 6mm ID
- B type: 50mm OD x 8mm ID
- Mini: 35mm OD x oval ID



Mounting Strip for Perfix

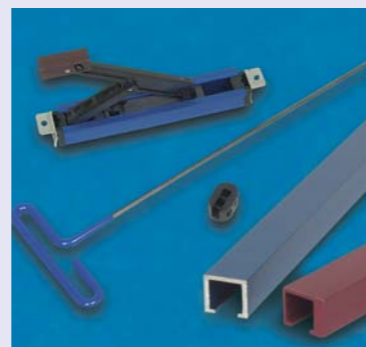

Flush Presser and Rails

- Slots into dieboards
- Enables any length of presser to be created

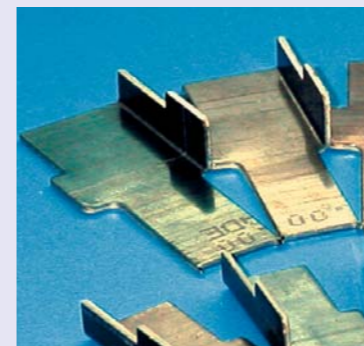
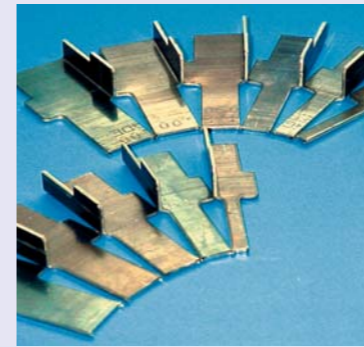

Pinpoint

- Cost effective stripping system
- Reduces bottom pins dramatically
- Reduces make ready times on and off press
- Does not compromise machine speed
- Good longevity
- Operator friendly
- Widths of 4, 6, 8, 10, 12 and 14mm
- Packed in 100 left hand and 100 right hand per box

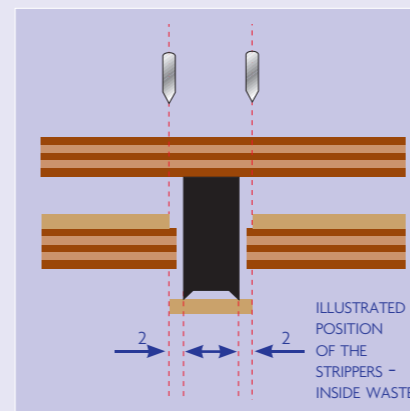

Countamat

- High quality durable counter material
- Developed by Channel for clean routing yet long run durability
- 1070 x 1040 sheet

THICKNESS	
0.4mm	0.8mm
0.45mm	0.85mm
0.5mm	0.9mm
0.55mm	1.0mm
0.6mm	1.2mm
0.65mm	1.4mm
0.7mm	1.6mm
0.75mm	

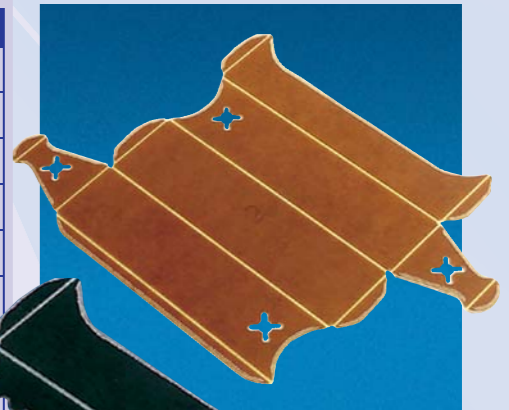

WITH OR WITHOUT
BACKING
ADHESIVE



Counter Locating Pins

- For location of counters



Ejector Rings

- Ejector for the pertinax locating pin